

Dispenser Ice Maker Manual

MODEL : ID-150AN, ID-0300-AN

- ※ Please check the voltage specification.
If the voltage specification is different, it can not be used.
- ※ This product is designed for indoor installation.
Please be sure to install it indoors.
- ※ The external appearance, design, color, and/or components
of this machine may be changed without prior notice for the sake
of the Company's product manufacture.
- ※ Please read the preparations for safety.
- ※ For maximum hygiene, be sure to clean and sterilize the product
on a daily basis.

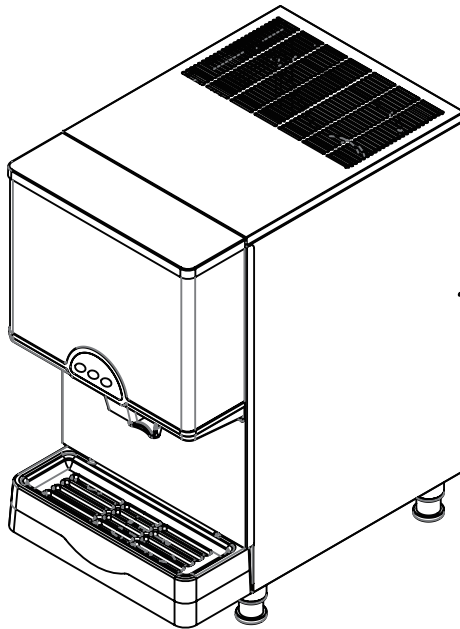

INDEX

1. Safety Precautions	3~8
2. Product Specification	9
3. Appearance and Size	10~11
4. How to install	12~16
– The installation place	12~13
– Panel disassembly method	14
– Connection method for water supply and drainage	15
– About grounding	16
5. How to start the product	17~20
– Button operation	18
– Function button description (FND display window)	19
– Three drainage functions	20
(forced drainage, automatic draining, water drainage)	
– Stop switch	20
6. Required precautions to prevent frost	21
– Water removal in water tank and evaporator	21
7. Maintenance, repair and disinfection	22~25
– Maintenance schedule	22
– Cautions for cleaning the external panel(stainless steel)	23
– How to clean and disinfect	24~25
8. Circuit diagram	26
9. Error type	27
10. Before Requesting Service	28
11. Product Warranty	29
12. Part List	30~31

1. Safety Precautions



Warning

When there is a risk of causing physical problems such as death or serious injury in the event of improper use.



Caution

When injury or damage to property such as house or furniture may occur in the event of improper use.



SHOULD BE DONE



PROHIBITION



DO NOT
DISASSEMBLE



DO NOT
TOUCH



DISCONNECT
POWER PLUG



GROUNDED

Warning

Please check the voltage specification.
If the voltage specification is different,
it may cause malfunction or accident.

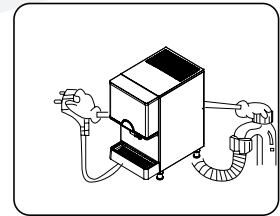

Use a single receptacle for the ice machine.

- ◆ An electrical fire may be caused by a receptacle holding more than one item.
- ◆ Do not use an adapter or an extension cord.

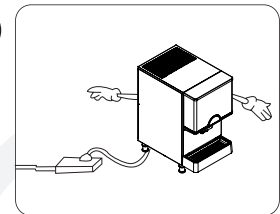

Clean the plug

Clean the plug if covered in foreign material or dust etc.
with a clean, dry towel.

- ◆ A fire may occur if plug is not cleaned.

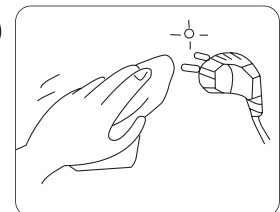



Warning

Do not place heavy objects or containers containing water on the ice maker.

- ◆ The objects or containers may fall and cause water to leak and the insulation may be weakened, resulting in a fire due to a short circuit.

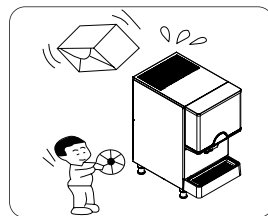

Do not install the product in a humid place or where there is a risk of water splashing.

- ◆ Insulation may be weakened, resulting in short circuit, electric shock, or fire.

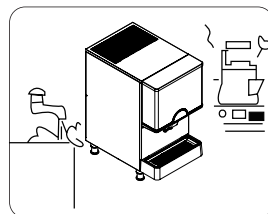

Do not use

If the product malfunctions, such as smoke or burning smell, unplug the power cord to stop operation.

- ◆ If you continue operating in abnormal conditions, there is a risk of fire or electric shock.

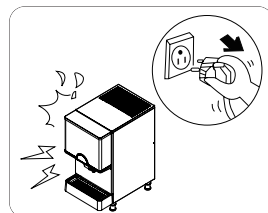

Do not use

Do not use flammable spray around the ice maker.

- ◆ Risk of explosion or fire.

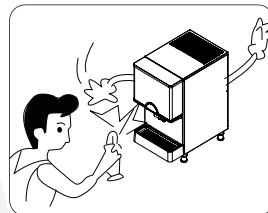

Do not use

Do not use if the outlet is loose or has a problem.

- ◆ There is a risk of fire due to electric shock or short circuit.

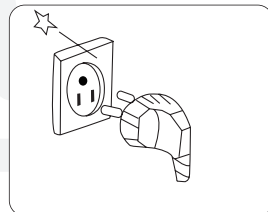



Warning

Prohibition

Do not bend the power cord severely, or allow it to be pressed by a heavy matter, which can cause damage to the cord.

- ◆ There is a danger of a current leak, electric shock and/or fire.
- ◆ Be sure to contact the customer service center if the power cord or plug get peeled or damaged.

Do not forcibly apply force or shock to the product.

- ◆ It may cause damage to the product.

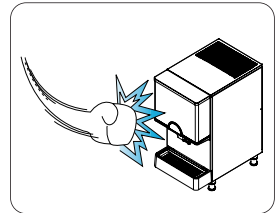

When the power plug is damaged, do not replace it arbitrarily and contact the service agency.

- ◆ It may cause an electric shock or fire.

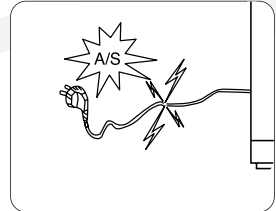

Do not move the product by pulling the power plug.

- ◆ It may cause a failure or electric shock.

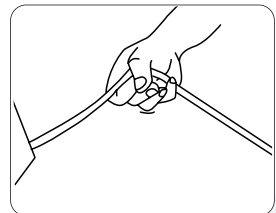

Be sure to use the grounded consent.

- ◆ It may cause a failure or electric shock.

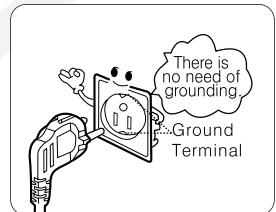

Do not pull off the power plug.

- ◆ It may cause a failure or electric shock.

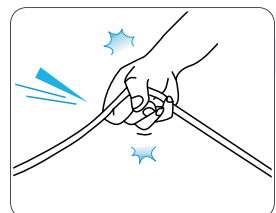



Warning

Disassembly forbidden

Do not modify or repair the product yourself.

- ◆ Ignition or abnormal operation is dangerous and may cause more trouble.

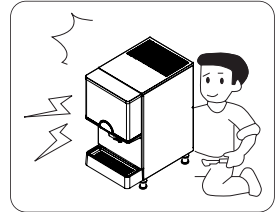

Prohibition

Do not allow electrical cords or plugs to be pinched or twisted.

- ◆ The cord or plug may be peeled and there is a risk of fire or electric shock.
- ◆ If the cord or plug is peeled or damaged, be sure to ask the service to replace it.

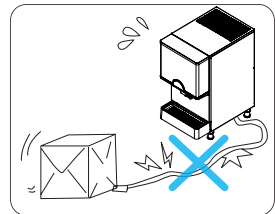

Prohibition

Do not let children hang on the product.

- ◆ There is a danger of the ice maker twitching or falling, resulting in injury.
- ◆ In particular, please do not let children hang on the reservoir not fixed to the product.

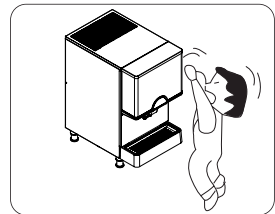

Do not touch

Do not touch or pull on the power plug with wet hands.

- ◆ There is a danger of electric shock.

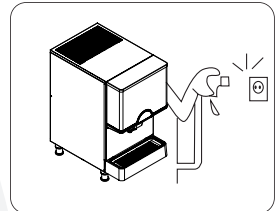

Do not touch

Do not damage the inside of the ice maker with a sharp tool.

- ◆ The ice reservoir may break or become damaged.

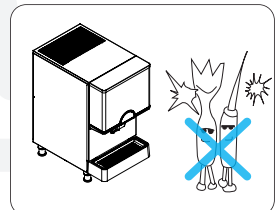



Warning

Disconnect power plug

When not in use for a long time, remove ice and water (to prevent winter frost), and unplug the power cord from the outlet.

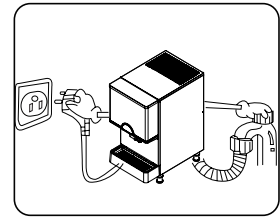

Disconnect power plug

When cleaning dust or replacing parts, unplug the power plug first.

- ◆ It may cause electric shock or fire.

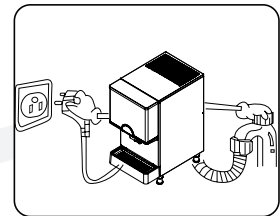

Disconnect power plug

When unplugging, grasp the plug body and remove it

- ◆ It may cause fire or spark when unplugged by plug wire or driver.

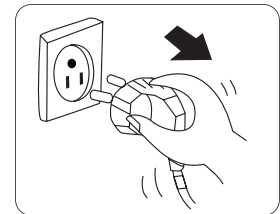

Grounded

Please be sure to ground.

- ◆ There is a risk of machine failure or electric shock due to short circuit.

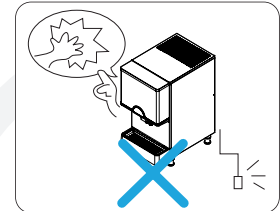

Do not connect multiple Products to a single outlet.

- ◆ Do not plug in multiple plugs at the same time. Connecting multiple plugs to a power strip will cause a fire.

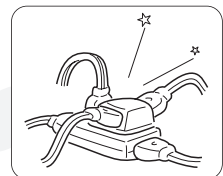



Caution

Caution

If there is a risk of slippery water or oil on the floor near the ice maker, please wipe it.

- ◆ There is a risk of injury if you slip on the ice maker or get hands or feet in the bottom of the side.

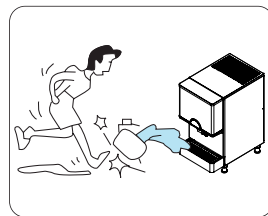

Hand over

When transferring this ice maker to another person, please hand it along with the instruction manual

- ◆ New users need a manual for safe use.

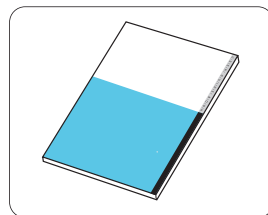

Do not put your hands or feet on the bottom of the ice maker.

- ◆ The bottom of the ice maker have iron plates and various parts which may cause injury.

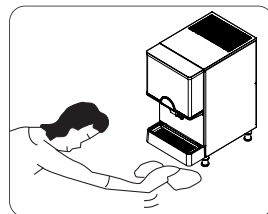

If you unplug the power plug from the wall outlet and plug it back in again, wait at least 5 minutes before reinserting.

- ◆ If it is plugged in immediately, it may cause a trouble in operation of the freezer and it may cause malfunction of the ice maker.

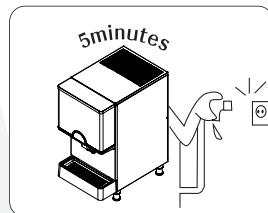

For areas where water contains much calcareous sediments, be sure to install a calcium filter at the water inlet port (calcium may reduce the lifecycle of the product).

2. Product Specification

Category		Specification
Model		ID-150AN, ID-0300-AN
Ice shape		Nugget
※ Maximum capacity (lb / day) Ambient temperature 70 °F, Water temperature 50 °F		297 (135 kg)
Storage capacity (lb)		11
※ Size (W X D X H inch) – Foot excluded		16.6 X 25 X 28
Power Supply		AC 115 V 60 Hz, 1PH
Current consumption		5.8 A
Weight	Before packaging	145.5 lb ± 1 lb (66 kg)
	After packaging	178.5 lb ± 1 lb (81 kg)
Compressor		3/8 HP
Condensation method		Air-cooled
Refrigerant		R-404A 11.29 oz
Deceleration motor	Power Supply	AC 115 V 60 Hz, 1PH
	Rated output	80 W
Discharging method		Solenoid
Installation environment standard	Specification	50 ~ 100 °F (10~38 °C)
	Water temperature	50 ~ 89.6 °F (10~32 °C)
	Supply water pressure	0.1 ~ 0.5 Mpa

※ Maximum production is based on ambient temperature 70 °F(21 °C) and water temperature 50 °F(10 °C).

However, the deviation may occur depending on the conditions of the installation environment, and the deviation may increase at high temperature conditions such as the summer season.

※ ※ Depending on the specifications of the reservoir, the size may be different, please check before purchase.

3. Appearance and Size

Unit : inch

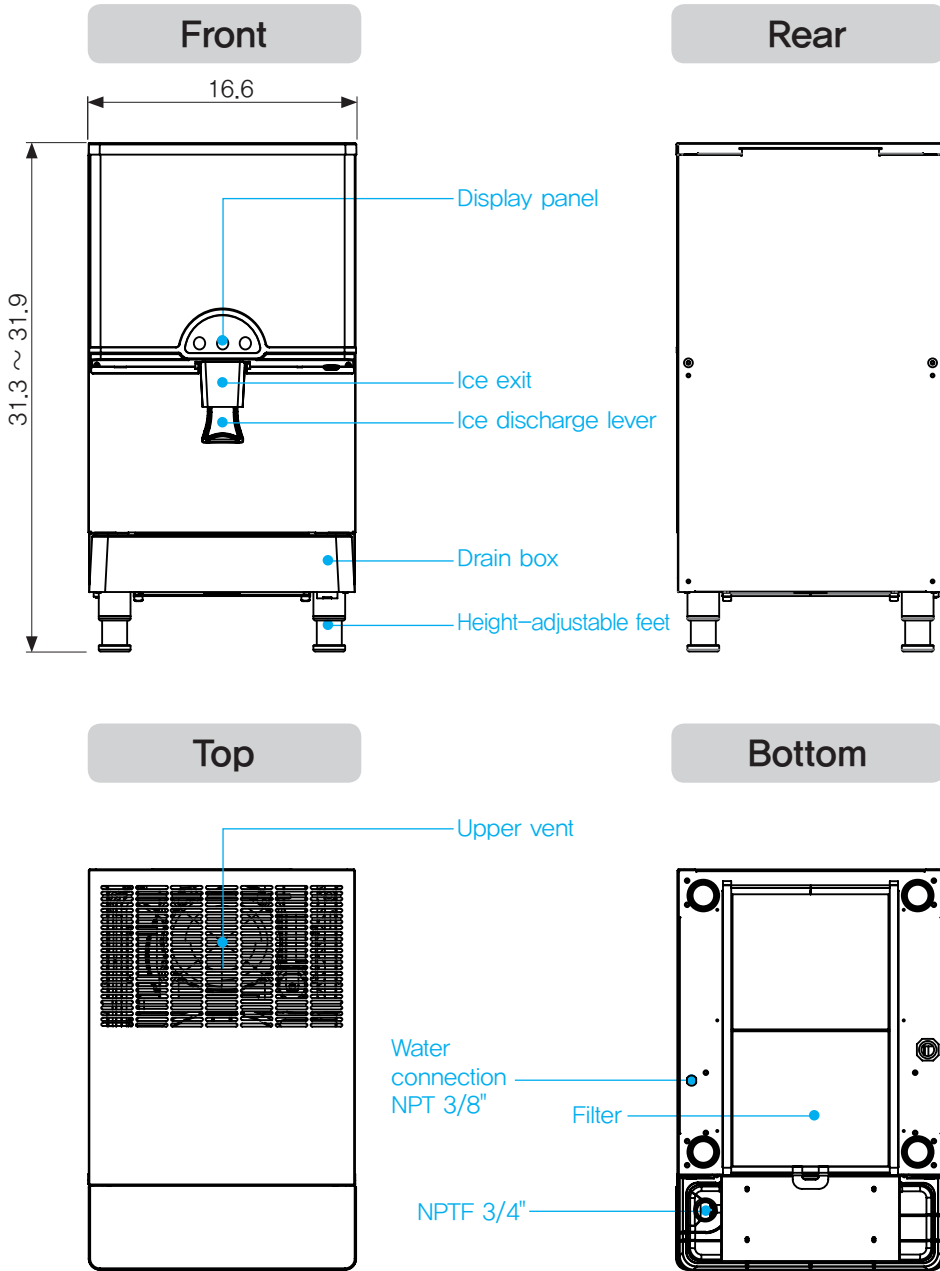

Left side

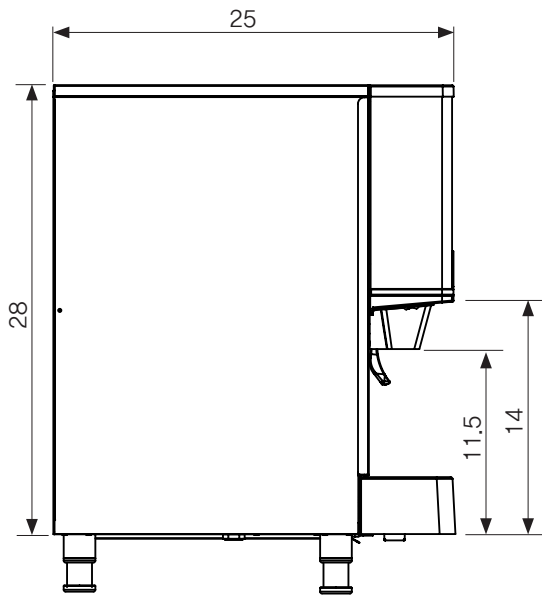

Right side

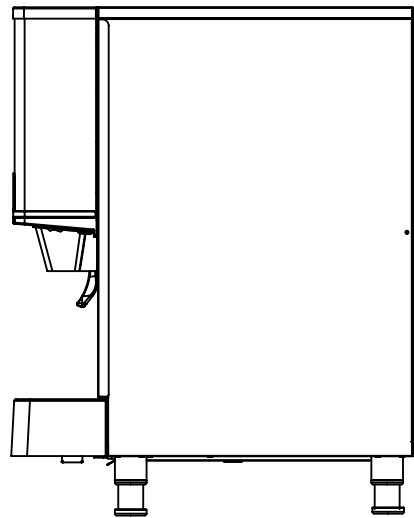

4. How to install

The installation place is like this ...

⦿ Where there is no heat source ...

- ◆ Install in a place where there is no heating device such as a fireplace or a gas range, and do not install in an area outside the range of 50 ~ 100.4 °F.

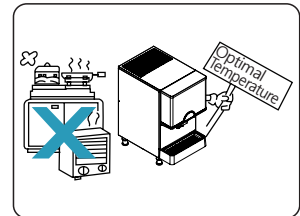

⦿ Where the space with the wall is reserved ...

- ◆ For normal operation, install the ice maker at least 7.8 inch away from the wall.
- ◆ For cleaning and maintenance of the auger, 39.4 inch space should be reserved above the top of the ice maker.

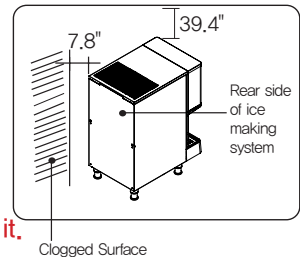

- ※ Never block the upper vents and do not place any load on it.

[Please follow the procedures when moving the machine]

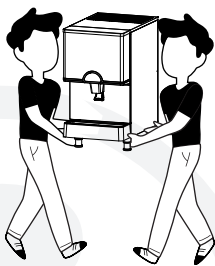

(O)

- ※ Two people should hold the bottom of the machine together to move it.

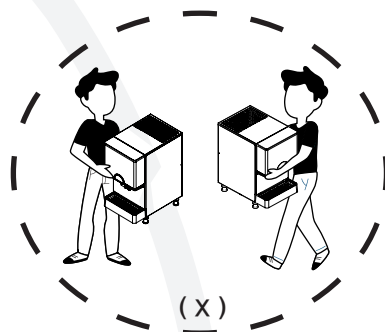
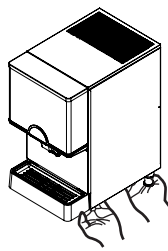

(X)

- ※ Do not hold onto the door of the machine. It might damage the door.

⦿ Where good ventilation is secured...

- ◆ If the ventilation is poor, the ICE MAKING ability will decrease.

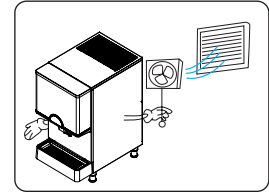

⦿ Installation is on a flat ...

- ◆ Unstable installation may cause vibration and noise. (Installed within 1 °)
- ◆ It is recommended to install it on a flat surface because there is a possibility that the product will fall and cause injury when the installation is made in a sloping place.

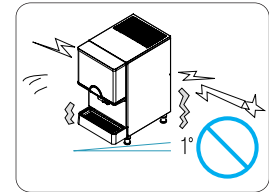

⦿ Please install in hygienic place.

- ◆ Ice is used for edible purposes, so please always install the product in a sanitary and clean place.

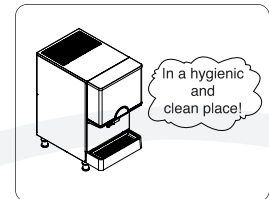

⦿ Installation should be indoors.

- ◆ Install the drain at an angle so that drainage is good.
- ◆ Do not install outdoors.

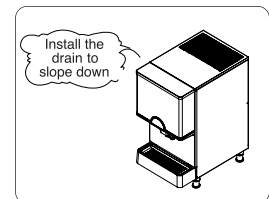

⦿ Install in a child-restricted area.

- ◆ Please be careful about the safety accident of a child and do not let dangerous jokes such as picking up the ice in particular.

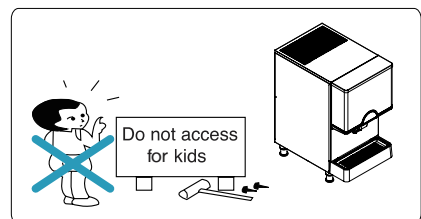

Warning

◆ Make sure to observe the following.

- Since the product makes use of water, proper water supply and draining facility are required.
- Water may leak during installation or operation for diverse reasons. Thus, proper draining must be prepared. Since there is danger of electric shock due to moisture from leak, be sure to observe the following:
 1. When installing the product indoors, be sure to have a natural drainage facility and make the floor waterproof, especially if the floor may get damaged due to leak.
 2. A draining outlet must be available at the installation site; be sure to connect the drain hose.
 3. Make sure that the floor is sloped so that any leaked water gets drained away even if the drain hose gets dislodged or damaged. Install a water overflow prevention wall to prevent damage.
- ※ Adjust the height by turning the footing if the floor is sloped to set it stably.
- ※ The manufacturer will not be liable for any problem arising from failure to comply with the warnings above, dislodged / damaged water supply, or inappropriate drain facility.

Panel disassembly method

1. Upper panel: Open the front door and lift the upper panel, then the back magnets will be separated and disassembled.
2. Front panel: Remove the lower set screws of the drain box, then loosen the set screws on the top of the front panel and pull out the front panel taking both sides.
3. Side panel: Open the door, loosen the screws on the top of the front panel, push the front panel forward, and slide the side panel forward to remove it.

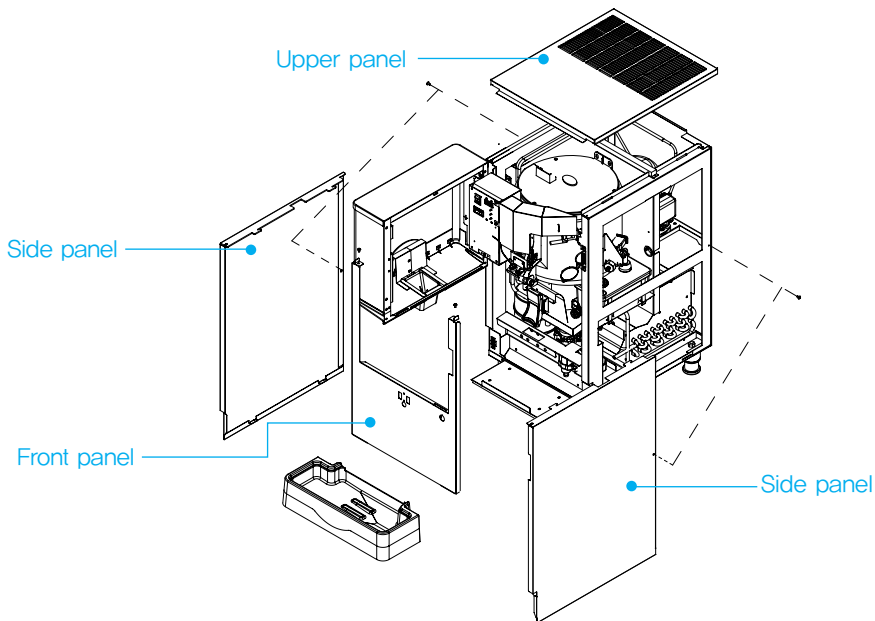

※ Apply the reverse sequence for reassembling the panels.

Connection method of water supply and drainage

[Connection of water and drainage hoses]

Division	Proper water temperature	Water pressure	Hose to be used
ICE MAKING water supply	50 ~ 89.6 °F	0.1 ~ 0.5 Mpa	NPT 3/8"
ICE MAKING drainage	—	—	NPTF 3/4"

If the temperature of the ICE MAKING water supply is too high, the amount of ICE MAKING may be reduced, If the water pressure is too low, it may not be possible to freeze. In this case, an auxiliary hydraulic pump should be installed.

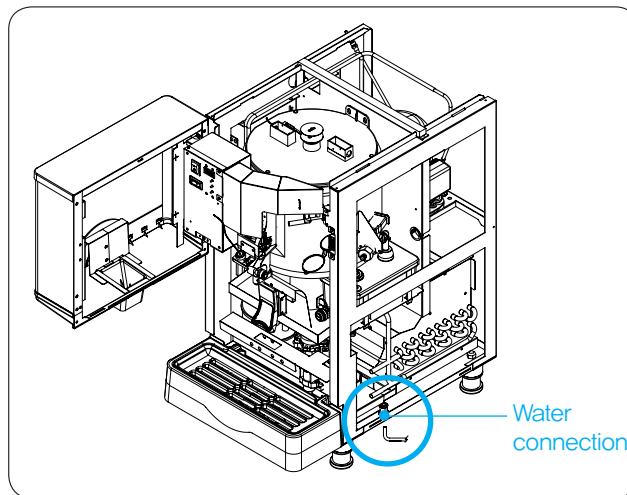

※ After the installation is complete, please operate the product and check whether there is leakage in the water supply and drainage parts.



Please connect a with an inner diameter of $\varnothing 0.78$ " or more for the ice making drain hose and the drain outlet should be 1.97" above the drain floor level. (If the drain outlet dip in the drainage, the drainage may flow back into the ice maker and damage the product and the floor.)

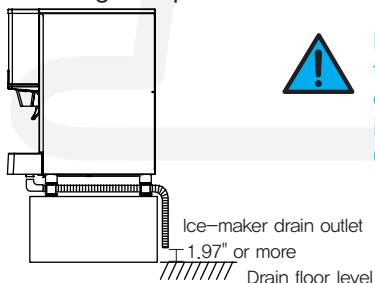

Be careful not to bend the drainage pipe during the installation and also confirm that the pipe is not exposed to fire or sharpness which may result in the drain burst. (This will become the cause of the PL accident and the manufacturer shall not be held responsible.)

About grounding

※ Please be sure to ground to prevent electric shock.

- ⦿ Grounding method – When there is grounding terminal
If you are using an AC outlet with ground terminals, you do not need to ground it separately.

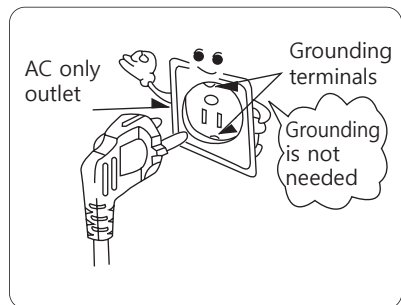

- ⦿ Grounding method – Without grounding terminal
If you are using an AC outlet without a ground terminal, connect the ground wire to the copper plate and bury it in the ground.

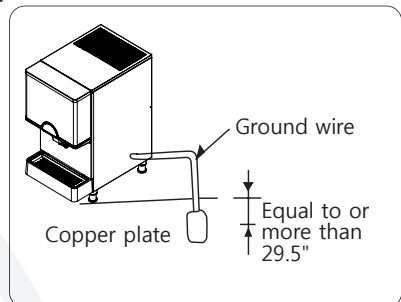

Do not ground in these places.

Never connect to a gas pipe, water pipe, pipe, lightning rod, telephone line, or connection.

※ Plastic water pipes and non-insulated materials do not have a grounding effect.

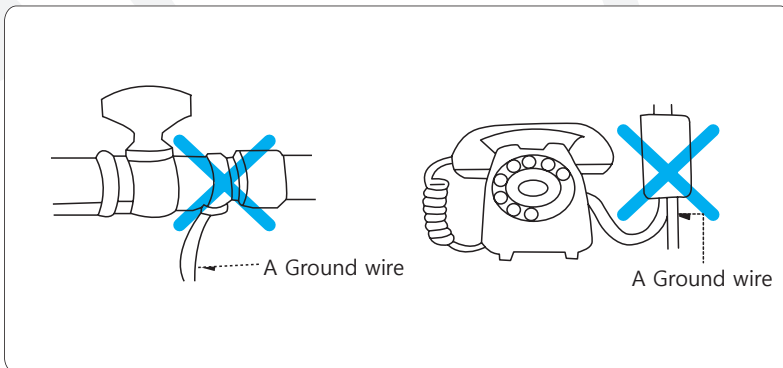

5. How to start the product

⦿ Water supply hose protection

Do not place heavy objects on the water supply hose leading to the water supply, or keep the hose from treading.

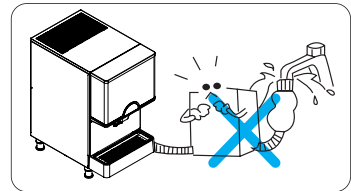

⦿ Proper water pressure, water temperature, ambient temperature

Please use this ice maker only in the area where water pressure is 0.1 ~ 0.5 Mpa, water temperature is 50 ~ 89.6 °F and ambient temperature is 50 ~ 100.4 °F.

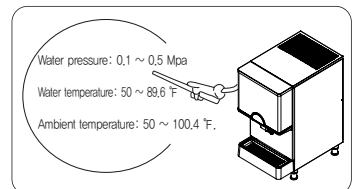

Please connect only the water you can drink.

1. Power connection

- ◆ Since this ice maker is only for 115V, please connect it to a dedicated outlet.

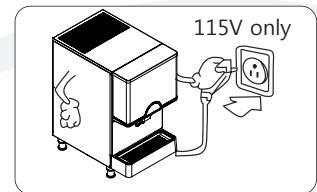

2. Water supply

- ◆ Please open the faucet and let the water supply.

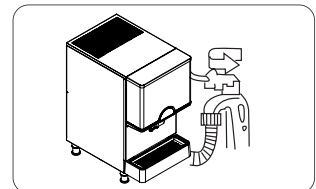

3. ICE MAKING operation

- ◆ Open the front door and turn on the power switch to start the ice making operation.
- ◆ Turn the ICE MAKING-OFF-WASH switch to ICE MAKING

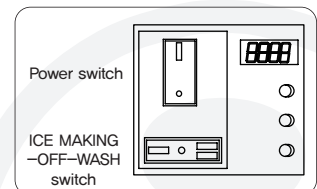

4. Start ice production

- ◆ There is a slight difference depending on the ambient temperature and water temperature, ice starts to be generated from about 3 minutes after starting the ice making operation, After about 70 minutes, the reservoir will be full of ice. (You can use ice after about 10 minutes.)

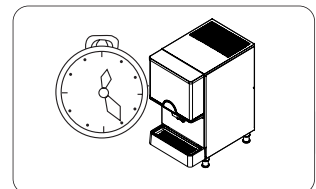

Button Operation

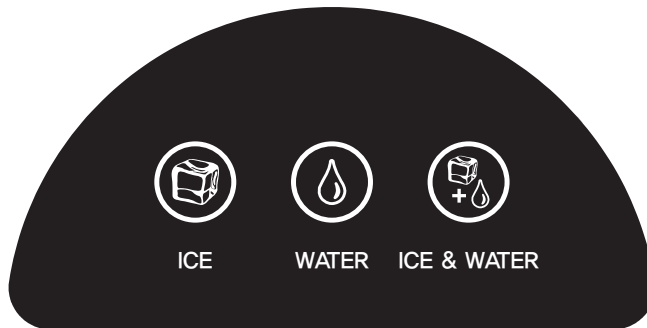

ICE button lamp

- If you turn on the power, this will always come in first. The initial water subtraction is done three times and then the ICE MAKING operation is proceeded. If you put the cup in the ice exit, you can discharge the ice for the time set in F1.

WATER button lamp

- Press the button to light up. If you put the cup on the ice exit, you can discharge the water for the time set in F1.

ICE + WATER button lamp

- Press the button to light up. If you put the cup on the ice exit, you can simultaneously discharge ice and water for the time set in F1.

When ERROR occurs

- ICE–WATER–ICE & WATER button will flicker in order and will disappear when restarting after the action against the ERROR.

Service cycle setting notification (parts check / replacement cycle notification)

- If the motor is running for more than 10,000 hours, the corresponding lamp blinks for 5 seconds in the initial stage of the ice maker.
- If the motor is operated for more than 11,000 hours, all the buttons will blink for 5 seconds in 1 hour cycle.

※ If all the buttons are flashing, it is a signal to check / replace regular replacement parts and you should contact the customer service center (paid service).

Failure to check / replace parts may result in higher repair costs.

Function Button Description (FND Display Window)

F. 1 (Maximum Discharge Time)

- ① SOLENOID Maximum operating time adjustment function.
- ② 3rd, 4th digits: 20 seconds (5 seconds ~ 30 seconds, Set Unit of one second).

F. 2 (Complete removal of ice in the reservoir)

- ① This function can be entered in "OFF" state of ICE MAKING–OFF–WASH switch.
- ② Press two buttons (WATER, ICE) simultaneously for 3 seconds and Button part LED lights up.
- ③ Press the discharge lever for continuous operation of SOLENOID and the motor. **Keep 'ON' state.**

F. 3 (Automatic ice discharge function)

- ① When ICE, WATER & ICE button is selected, ice is automatically emitted for the set time.
- ② Automatic operation is not possible when OFF is set. (Manual operation)
- ③ Automatic discharge is performed for the set time of At01 ~ 99.

F. 4 (Initial water subtraction function)

- ① It operates first when "ICE MAKING" switch is operated.
- ② FND 1st, 2nd digits (drain time) 30 seconds (oF ~ 99 seconds, Set Unit of one second)
- ③ Water supply operation after drainage to high water level.
- ④ FND 3rd, 4th digits (number of repetitions) Standard: 3 times (1 ~ 9 times)

F. 5 (Automatic drain function)

- ① It operates when "ICE MAKING" switch is operated.
- ② FND 1st, 2nd digits (drain time): 2 seconds (oF ~ 9 seconds, Set Unit of one second)
- ③ FND 3rd, 4th digits (drain interval): 1.0 hour (0.5 ~ 9.5 hours, every 30 minutes)

F. 6 (ICE + WATER volume control)

- ① 1st, 2nd digits Ice time Default 5 seconds (up to 99 seconds)
- ② 3rd, 4th digits Water time Default 5 seconds (up to 99 seconds)

※ Setting value reset function
– Pressing three buttons of UP, DOWN, and SET for 3 seconds at the same time will set all setting values to default values

F. 7 (UV LAMP time adjustment)

- ① 1st, 2nd digit lighting time Default 3 minutes (99 minutes possible)
- ② 3rd, 4th digits off time Default 1 hour (9 hours available)

F. 8 (Notify service period setting)

- ① A.1.0 After using 10,000 hours, the corresponding mode LED blinks for 5 seconds (for the first 5 seconds during ice making)
- ② A.1.1 After using 11,000 hours, all LEDs blink for 5 seconds (1 hour cycle)

F. 9 (Cumulative uptime)

- ① The FND display is displayed in year, month, day, and hour, and is displayed in order from right to left.
- ② Cumulative operation time of product is expressed in hour unit.
- ③ Calculation example: 12 months for 1 year, 30 days for 1 month, 24 hours for 1 day.

F. 10 (Change temperature unit)

Function of setting the unit of temperature in degrees Celsius or Fahrenheit

F. 11

Evaporation inlet temperature display

F. 12

Evaporation outlet temperature display

F. 13

Choose ice and water discharge method
ordE : Discharge ice first and then discharge water
join : Simultaneous discharge of ice and water

Three Draining Functions(Forced Draining, Automatic Draining, Water Draining)

- 1) Forced drainage function (Must be implemented to prevent freezing in winter storage. Please also use this function for cleaning the inside.)
 - Turn on the power switch and press the "DOWN + SET" button simultaneously for 3 seconds with any signal on the FND display. (30 seconds)
- 2) Automatic drain function (F. 5)
 - Turn on the power switch and turn the ice making switch to "ICE MAKING" to start the operation.

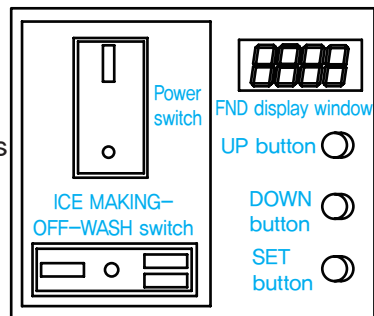

- ① FND 1st, 2nd digits (drain time): 2 seconds (oF ~ 99 seconds, Set Unit of one second).
- ② FND 3rd, 4th digits (drain interval): 1.0 hour. (0.5 to 9.5 hours, every 30 minutes)

- 3) Initial water draining function (F. 4)
 - Turn the power switch off and then on again (the ICE MAKING-OFF-WASH switch at "ICE MAKING" position) to operate the function.
 - ① Clean the water line and ice making cylinder thoroughly.
 - ② FND 1st, 2nd (drain time) 30 seconds (oF ~ 99 seconds, Set Unit of one second).
 - ③ Water supply operation to high water level after drainage.
 - ④ FND 3rd, 4th digits (number of repetition) Reference: 3 times (1 ~ 9 times).

Stop switch

With the power switch turned on, turn the "ICE MAKING-OFF-WASH" switch to center OFF, then the ice making stops and the motor runs for another 60 seconds. This function protects the motor by removing the ice remaining in the product. If you sell the remaining ice even when it is OFF, ice discharging will be done. (At this time, water, water + ice will not work.)

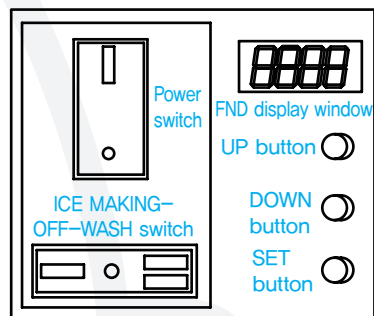

6. Required Actions to prevent frost

Water Removal in Water Tank and Evaporator



Caution

If the ambient temperature falls below 32 °F, water will freeze inside the machine and machine operation will be impossible.

If you do not use for a long period of time in winter, be sure to completely remove the ice making water inside the body by following the instructions below. If you do not remove the ice making water or if it is insufficient, it will cause serious damage to the product.

This shall not be guaranteed by the manufacturer and may result in a lot of repair costs. Please observe the following points.

1. Turn on the power switch and press the DOWN + SET button at the same time for 3 seconds with any signal on the FND window. Forced drainage will be done for 30 seconds.
2. Turn off the power switch and disconnect the power plug from the outlet.
3. Remove the upper panel → the front panel.
4. Remove the evaporator cylinder drain hose clamp and remove the hose, and wait until the ice in the evaporator cylinder completely melts down. (It is possible to remove internal water quickly by using compressed air gun etc.)
5. Reassemble the evaporator cylinder drain hose and tighten the clamp.
6. Assemble in the order of left panel → upper panel → front panel

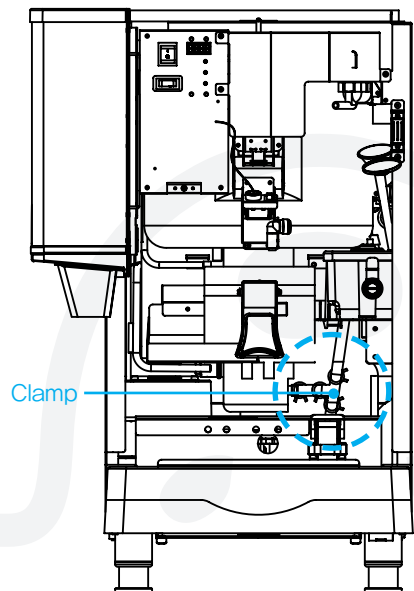
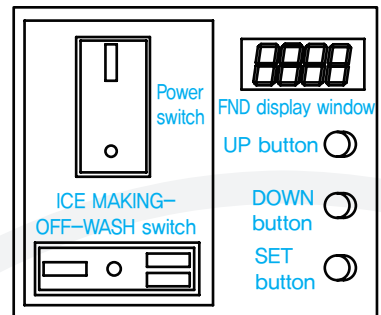

7. Maintenance, repair and disinfection

※ Please keep the product according to the instruction manual and label provided.



- Be sure to have a qualified service technician service the product.
- To reduce the risk of electric shock, do not touch or disassemble the parts of the ice maker.
- Before service
 - Turn off the power switch of the ice maker and the earth leakage breaker, and disconnect the power plug from the outlet.
- Choking hazard
 - After performing maintenance and repair, make sure that all components (such as fixtures, screws, bolts, etc.) are completely assembled.
 - Be careful not to let any components fall into the ice making compartment and ice reservoir.

Maintenance schedule

※ The following maintenance schedule is guideline.

※ Maintenance and repair should be done more frequently according to water quality, equipment usage environment and local hygiene regulations.

Inspection Schedule	Area	Contents
Daily	Chute	1. Clean the ice scoops with a neutral detergent. 2. Rinse thoroughly after cleaning.
Weekly	Air Filters (air-cooled)	1. Inspect for dust and wash dirt with warm water and neutral detergent.
Monthly	External water filter	1. Make sure that the pressure is adequate and make changes if needed.
	Outside of the ice maker	1. Wipe it with a clean, soft cloth, and use a cloth dampened with a neutral detergent to wipe away any accumulated dust or grease. 2. Clean the chlorine dye (green spots) with non-abrasive detergent.
	The bottom of the ice maker	1. Wipe clean with clean cloth and warm water.
Every six months	Ice maker and reservoir	1. Clean and disinfect according to the disinfection instructions given in the instruction manual.
	Evaporator condensate drain pan and Geared motor drain pan	1. Wipe clean with clean cloths and warm water, and slowly pour a cup of disinfectant solution (prepared as described in the instructions for disinfection in the manual) into the evaporator condensate drain pan. 2. Take care not to overflow the drain pan. 3. This disinfectant solution will flow out through the geared motor drain pan and drain passage. 4. Rinse repeatedly with a glass of clean water.
	Ice maker and reservoir	1. Always check that it is kept clean.
Every year	Ice exit fixing seal bolt	1. Check for leaks around the seal bolt. Tighten if necessary and replace O-rings. 2. Always replace the O-ring when loosening the seal bolt and tighten it again. If there is no O-ring, apply Loctite 243 or equivalent fixing agent so that it does not leak.
	Water supply valve and Drain valve	1. Close the shutoff valve to shut off the water supply line and drain the water. 2. Close the shutoff valve to shut off the water supply line and drain the water.
	Water Drain pipe	1. Check the water drain pipe and clean it if necessary.
	Condenser (air-cooled)	1. Inspect for cleaning. If necessary, clean with a brush or vacuum cleaner 2. If the dust adhesion is severe, spray the pin cleaning agent, clean the dust, spray it with clean water, rinse and dry with air gun.
	Ice maker	1. Inspect for oil marks, loose components, tightening parts and wires.
	Upper bearing (Ice exit head)	1. Check that 0.02 inch round bar or pin gauge (or clearance gauge) is inserted into auger and bearing clearance, and replace all upper and lower bearings (ice exit head and lower housing) (Paid service)
Every three years	Mechanical seal	1. Check for leaks in the bottom housing, and if there is a leak, disassemble the auger to replace the mechanical seal. (Paid service) (Water with a lot of calcium will shorten the life of replacement parts.)
	Upper and lower bearings, Housing O-ring, Mechanical seals, Evaporator cylinder, Auger	1. Please check. If the auger and bearing clearance exceeds the factory recommended value (0.5mm or less), replace both the upper and lower bearings. If the contact surface of the mechanical seal is worn, cracked, or scratched, replace it.

Cautions for cleaning the external panel(stainless steel)

※ How to remove rust

How to clean rusted parts

1. Rust spots in early stage

- Rust spots in early stage mean that the stainless steel itself is not severely affected, thus mild detergent or any commercially available cleaning agent will restore original state. Rust will be removed with ease and at low cost if regular cleaning is done at appropriate intervals.

2. Red rust

- Rust spots that are not removed after a short period of time will turn into thick reddish–brown rust and will damage the surface of the stainless steel. These are much harder to remove and the surface will not be fully restored; thus, it is important to remove rust spots early on.

If commercially available cleaning agents do not work, use sandpaper or a stainless steel brush to remove the rust before applying the agent for easier removal.

This process requires treatment, such as refurbishment after cleaning.

3. Rust from iron

- Rust from coming into contact with welding spatter, rust from the metal bar above the stainless steel part, or contact between the stainless steel parts and general metal parts are caused galvanic corrosion. This causes the metal to rust first, and it will eventually cause the stainless steel to rust too if it is not removed. As such, make sure to clean and remove rust immediately with a mild detergent. However, when the rust has gotten really bad, it must be removed with 15% nitric acid solution or commercially available stainless steel cleaner.

4. Rust from exhaust gas or acid rain

- In environments, such as a factory complex or heavy transport sites, the product will become contaminated in a short amount of time due to exhaust fumes or acid rain and rust spots will quickly form. Light rust can be washed off with a mild detergent or soapy water, but heavy rust will require 15% nitric acid solution or commercially available stainless steel cleaner.

5. Rust from salt deposit

- In environments, such as windowsills or pipes on the porches of an apartment complex, that are close to the seashore where the product may be directly exposed to the sea winds, STS304 or STS316 will get rusted in no time, and this will occur much faster than in other types of environments. These cases require special treatment, such as using painted stainless steel or regular cleaning.

6. Rusts from disinfectants or cleaning agents

- Sites, such as pools or public baths, that use chlorine–based agents to sterilize the water, especially those for cleaning bathrooms, contain chlorine content that attaches to and rusts the stainless steel surface. Thus, it is important to thoroughly wash off such agents after using them, and a 15% nitric acid solution or commercially available stainless steel cleaner are required for removing this type of rust.

How to clean and disinfect

※ The ice maker should be cleaned and disinfected at least twice a year.
More frequent cleaning and disinfection may be required.



Warning

◆ **Make sure to comply with the following.**

- Do not use ammonia-based detergent to prevent damage to the personnel or the ice maker itself.
 - Cleaning and sterilizing must be conducted in accordance with the instructions on the user manual.
 - Always wear protective gloves and goggles to prevent skin or eye from coming into contact with the sterilizing solution.
 - Do not use the ice made with the cleaning or sterilizing solution after cleaning and sterilizing.
- Make sure that no sterilizing solution is left on any part of the ice maker and the ice storage bin.

How to disinfect

Disinfection cleaning stage 1

(Disinfectant: mixed liquid of 0.04 L of NIKEL CLEANER / 1 L of water)

1. Inject 1.5L of disinfectant into the water tank and leave it for 10 minutes.
2. After activating in the cleaning mode, pour 3 liters of disinfectant evenly into the reservoir (hopper) while the Auger is operating.
3. After auto drain is completed after 5 minutes, turn off the 3-step switch and turn off the Main switch.
4. Inject 1.5 liters of disinfectant into the water tank and leave it for 10 minutes.
5. After operating Auger for 5 minutes by operating in the cleaning mode, after automatic drain is completed, turn off the 3-step switch and turn off the Main switch.

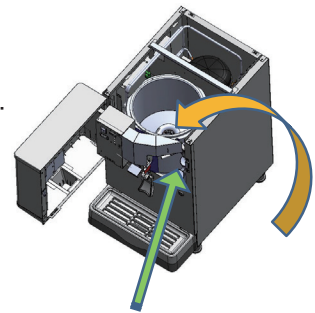

The water inlet to the water tank

Disinfection cleaning stage 2

(Sterilizing liquid: sterilizer 400 mL / distilled water 10 L)

1. After injecting 1.5L of sterilizing liquid into the water tank, leave it for 10 minutes.
2. After operating in the cleaning mode, pour 5L of sterilizing liquid into the reservoir (hopper) evenly while the Auger is operating.
3. After auto drain is completed after 5 minutes, turn off the 3-step switch and turn off the Main switch.
4. After injecting 1.5L of sterilizing liquid into the water tank, leave it for 10 minutes.
5. After activating in the washing mode and operating the Auger for 5 minutes, proceed to the water supply (manual, distilled water) after the automatic drainage is completed.
6. After the water supply is completed, the auger is operated for 1 minute, the water is automatically drained, and then the water supply is proceeded.
7. When the 6th step is carried out 3 times, the washing is completed. Water sample is taken during the last drainage for the bacteria inspection.

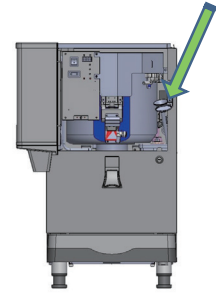

The area where the disinfectant and the sterilizing liquid is removed after the Agitator is removed.

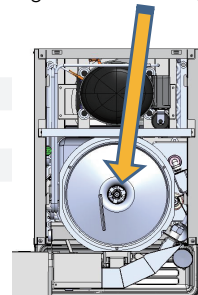

1. Disinfection wash

Dilute 10 L of warm water and 400 mL of 5,25% sodium hypochlorite solution (bleach).

(※ Dilution ratio may vary depending on the solution manufacturer, please refer to the solution manual).

If this is the minimum amount to be used, use more washing solution.

※ To ensure safety and maximum effect, please use the washing solution immediately after dilution.

※ Ice machine cleaner & sanitizer has to comply with 40 CFR § 180.9403 or registered with the USEPA Office of Pesticides Program, Antimicrobials Division as a food contact ice machine cleaner & sanitizer.

2. Disinfection procedure – initial

- 1) Shut off the water supply by closing the valve of the water supply line and make sure that the power switch is turned to “OFF” position and the power plug is disconnected from the outlet, and then remove the front panel and the upper panel.
- 2) Pour the disinfectant solution over the water inlet until the evaporator assembly and the water tank are full.
(Until the disinfecting solution overflows to the drain box)
- 3) Open the top cover and disassemble the ice reservoir lid.
- 4) Disassemble packing, bush, etc. inside the lid.
- 5) Turn the Agitator to the left to disassemble it.
- 6) Remove the Ice Base Plate.
- 7) Disinfect the inside of the reservoir and the removed parts for 10 minutes and wipe them.
- 8) Remove Spout, clean for 10 minutes and wipe.
- 9) Please thoroughly rinse all parts with clean water. (※ If there is residual washing solution, it will cause corrosion.)
- 10) Assemble all parts in the correct position.
- 11) Connect the power plug to the outlet, turn the power switch to “ON” , turn the ICE MAKING–OFF–WASH switch to “ICE MAKING” and keep the operation until the disinfectant solution is exhausted and the ice production stops.
- 12) Switch the ICE MAKING–OFF–WASH switch to the "WASH" position and let the remaining water drain out for 5 minutes.
- 13) Turn the power switch to “OFF” and disconnect the power plug from the outlet.

3. Disinfection procedure – final

- 1) Mix the disinfection solution in a new bowl.
- 2) Check that the water valve is closed, the power switch is turned off and the power plug is disconnected from the outlet, and then remove the front panel and the upper panel.
- 3) Pour the disinfectant solution over the water inlet until the evaporator assembly and the water tank are full.
(Until the disinfecting solution overflows to the drain box)
- 4) Leave the ice maker for 10 minutes before operating the ice maker.
- 5) Connect the power plug to the outlet, turn on the power switch, and turn the ICE MAKING–OFF–WASH switch to 'ICE MAKING' until the disinfectant solution is exhausted and the ice stops generating.
- 6) Switch the ICE MAKING–OFF–WASH switch to 'WASH' and drain the remaining water for 5 minutes.
- 7) Switch the ICE MAKING–OFF–WASH switch to "ICE MAKING" and open the valve of the ice–maker water supply line so that water can be supplied to the water tank.
- 8) When the geared motor starts to operate, switch the ICE MAKING–OFF–WASH switch to the 'OFF' position.
- 9) Switch the ICE MAKING–OFF–WASH switch to 'WASH' and discharge the remaining water for 5 minutes.
- 10) Turn the ICE MAKING–OFF–WASH switch to 'ICE MAKING' position to generate ice for 30 minutes, then turn off the power switch.
- 11) Pour warm water into the ice reservoir to dissolve the ice and drain it. Use a neutral detergent to wash the reservoir. After washing, rinse thoroughly with clean water.

8. Circuit Diagram

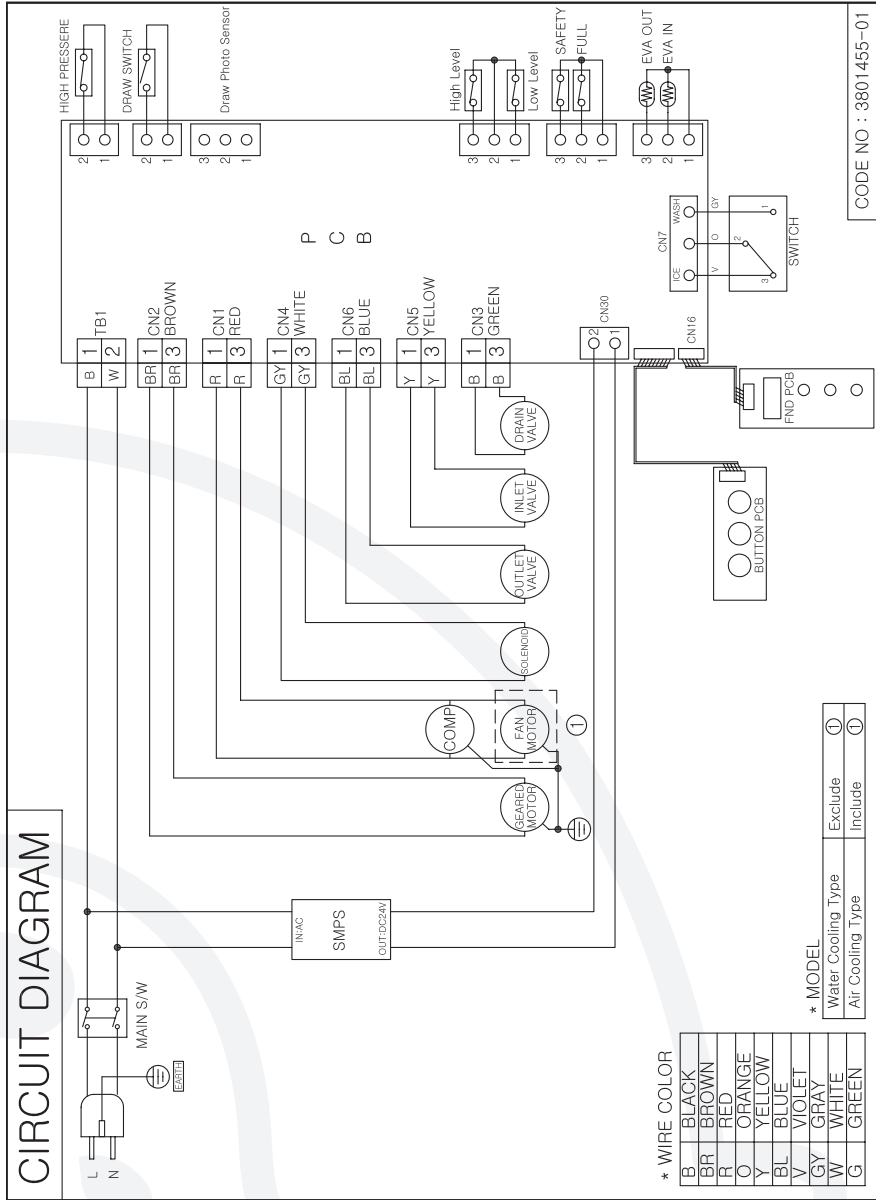

9. Error Type

- ① When Error occurs, the front use button (ICE–WATER–ICE & WATER) of the door lights alternately to the left and right. Restart after action.
- ② When the button is lit alternately to the left and right, open the door and press the bottom setting button of the control buttons, Error display will appear.

Display	Error type	Causes	Action	Release	Operation
Er01	Evaporator temperature error	When the Evaporator temperature is 32 °F or more after 30 minutes passed during the ice making	Check refrigerant leakage Check sensor and attachment abnormality	Resupply power after resolving cooling problem	Stop ice making
Er03	Evaporator temperature error	When the Evaporator temperature is over 23 °F after 30 minutes passed	Check refrigerant leakage Check sensor and attachment abnormality	Resupply power after resolving cooling problem	Keep on ice making
Er06	Temperature sensor error	Displayed when temperature sensor is open or shorted.	Check sensor and attachment abnormality	Start operation after sensor part repair	Stop ice making
Er13	High pressure switch error	Condenser dust, fan motor failure, cold cycle abnormality, etc.	Remove dust, Check Fan motor Check for abnormal cold cycle	Automatic return after action	Stop compressor, Stop motor after operating 10 seconds.
Er14	High pressure switch error	Occurs when High pressure switch is OPEN 3 times or more	Contact service representative	Start operation after action	Stop compressor, Stop motor after operating 10 seconds.
Er15	Water supply error	When water level is not detected by the water level sensor due to no water supply for 120 seconds.	Water supply pressure check Water level sensor check	Start operation after action	Stop ice making
Er16	Water level sensor defect	At the start of ice making, when the upper and lower limits are not detected by the water level sensor for 60 seconds	Replacement of Water Level Sensor	Start operation after action	Stop ice making
Er25	Motor restraint	Occurs when Evaporator inlet / outlet temperature is 3.2 °F or less for 2 minutes. Poor water supply, Agitator restraint, Ice jams due to scale	Unlock ice jams Check water supply line Check motor restraint fault	Start operation after action. Machine stops after 3 repetitions	Stop ice making

10. Before Requesting Service

Make sure to check the following if the product is operated inappropriately.
 If the issue persists, contact the local distributor where you purchased the product or the customer service center.
 Please provide the information on the warranty when you contact us.
 (Model, serial number, name of distributor, date of purchase and detailed description of issue)

Operational status	What to check	Measures
1. Ice maker does not work	1. Is power supplied?	Plug the power cord.
	2. Is circuit breaker ON?	Turn on the circuit breaker on the back of the product.
	3. Is the power supply of the machine using rating volts?	Check the power and make sure to use the proprietary plug.
	4. Is the power switch on the front turned on?	Make sure to set the front power switch at 'ICE'.
2. Water is not supplied.	1. Is water valve closed?	Open the water valve.
	2. Is water inlet hose installed properly?	Check and take necessary measures.
	3. Is water working?	Check the water source.
	4. Is water valve working?	Check and contact the customer service center.
3. Takes too long to make ice cubes.	1. Ice maker is too dirty(too much dust). (Air cooled type)	Disassemble the front cover, remove the dust filter and clean it with a vacuum cleaner. Too much dust deteriorates performance and may make the product use too much power.
	2. Is ambient temperature not too high or low?	Operational temperature is 50 ~ 100.4 °F. Make sure that ambient temperature is appropriate.
	3. Is the water inlet valve too clogged or has too much dreg?	Disassemble the valve and remove foreign objects from the filter. Make sure that the tap is closed for this.
4. Ice maker is too noisy or makes strange noises.	1. Is the floor level or solid enough?	Make sure that the floor is fully even.
	2. Does either front or back of the ice maker come into contact with the wall?	There must be a gap wider than 19.7 inch. from the walls.
	3. Is supplied water too cold?	Water temperature needs to be 50 ~ 89.6 °F.
	4. Does the ice making device make too much noise?	Set the power switch to 'OFF', melt all ice and set the switch back to 'ICE'. Contact the customer service center.

11. Product Warranty Period

If you did not receive or lost a warranty card or receipt, or if it is difficult to confirm the date of purchase due to other reasons, the warranty period will be calculated from 6 months after the date of manufacture.

[Free repair]

1. In the event of performance or functional failure occurring under normal use within the warranty period.

[Paid Repair]

1. Warranty expired products
2. If the product is not installed correctly at the initial stage of the delivered product and/or at the shop (customer) and re-installed
3. In case of installation due to movement of the product, moving, etc.
4. Failure due to defect of other company's product
5. If the fault occurred due to incorrect use of the electric capacity
6. In the case of malfunctions caused by consumables or options not specified by us
7. Failure or damage due to external impact or dropping
8. Failure due to natural disasters (lightning, fire, earthquake, flood, tsunami, etc.)
9. Consumable parts have reached end of life (packing, cleaning brush, etc.)
10. If the malfunction occurred by putting foreign substances into the product (water, drink, coffee, toy, etc.)
11. In case of product breakdown or malfunction due to external impact during installation and use
12. If the product malfunctions due to non-genuine parts or consumables
13. Failure due to failure to install according to the installation standards in the instruction manual.
14. If the customer disassembles the product and the accessories are lost or damaged.
15. If a person other than our engineer breaks down due to repair or modification of the product
16. If the malfunction occurred due to failure to observe the "Safety warnings and precautions" described in our instruction manual.
17. If the fault occurred due to freezing and clogging of the supply and drain pipes

12. Part List

※ Ice Maker Unit

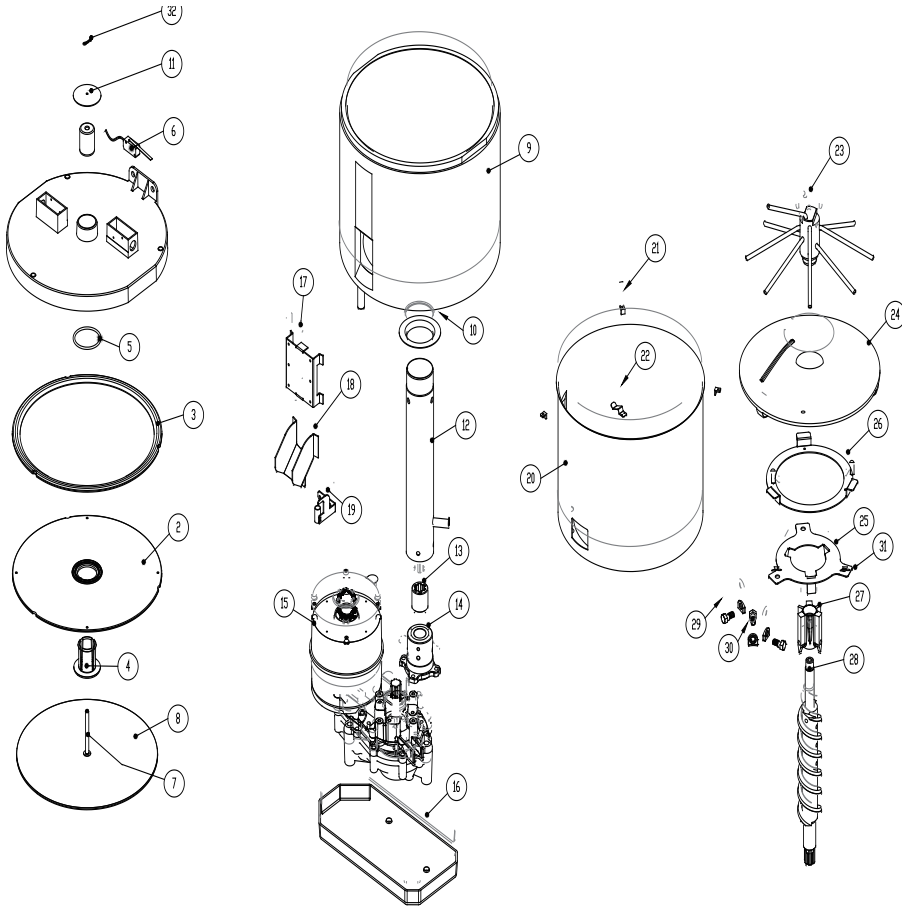

NO	Part name	Part code	16	GEAR MOTOR DRAIN PAN	318039100
1	COVER STORAGE BIN	318038800	17	BASE SHUTE	301179100
2	COVER IN STORAGE BIN	318038900	18	ICE GATE	301179200
3	PACKING COVER STORAGE BIN	303037000	19	WATER SPOUT	301180500
4	BUSHING COVER STORAGE BIN	318039200	20	HOPPER	301177400
5	O-RING	303037400	21	COVER NUT	301176800
6	MICRO SWITCH	355018100	22	STOPER PAN	317205700
7	SHAFT PLATE SENSOR	314043600	23	AGITATOR ASSY	436003300
8	PLATE SENSOR	318039000	24	ICE BASE PLATE	301177500
9	HOPPER FOAM ASSY	442008500	25	EVAPORATOR SUP BASE	317205500
10	HOPPER BASE PLATE	301177600	26	EVAPORATOR FORM PE	317205600
11	PIPE DRAIN	325148300	27	EXTRUDING HEAD	603001300
12	EVAPORATOR PIPE ASSY	409043200	28	AUGER	430005000
13	SPLINE COUPLING	612000800	29	CUTTER BOLT	214030300
14	HOUSING ASSY	491000900	30	HEAD LOCKING WASHER	211008000
15	AUGER MOTOR	406026000	31	M5나비너트	215018900

※ Water Reservoir & Cooling Unit

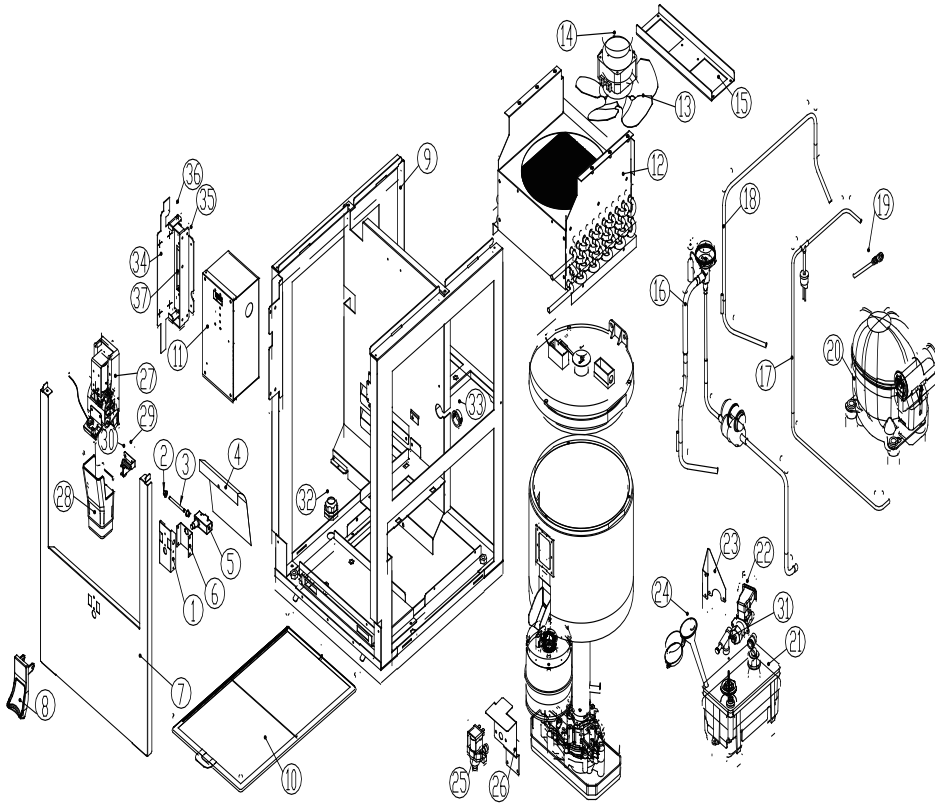

NO	Part name	Part code	19	CHARGE NIPPLE ASSY	459000400
1	BKT BASE SHUTTER LEVER	301178400	20	COMP	3940041000
2	POM BEARING	310006400	21	WATER RESERVOIR ASS'Y	470002200
3	SHAFT SHUTTER LEVER	314043500	22	WATER VALVE	340029400
4	FILM MICRO SWITCH	120001500	23	BKT WATER SOL VALVE	301179800
5	MICRO SWITCH	355024200	24	FUNNEL	318039300
6	BKT MICRO SWITCH	301178500	25	DRAIN WATER VALVE	340029500
7	FRONT PANEL DOWN	317206700	26	BKT DRAIN WATER SOL VALVE	301179900
8	SHUTTER LEVER	309005800	27	ASSY SHUTTER	427059300
9	ASSY ANGLE	444016000	28	SPOUT	318038700
10	AIR FILTER	640009000	29	WATER SPOUT	301180500
11	ASSY CONTROL BOX	426070900	30	STEM ELBOW	398013800
12	ASSY CONDENSER	411032400	31	CONTROL VALVE	395005700
13	FAN	308003700	32	CABLE GLAND	227001200
14	FAN MOTOR	353021501	33	GROMMET BUSHING	232003500
15	BKT FAN MOTOR	332044300	34	BKT IN HINGE	301165100
16	EXPENSION VALVE	340029000	35	HINGE BASE	301178100
17	DISCHARGE PIPE ASSY	325148600	36	HINGE M(STS) R-UP	321006800
18	SUTION PIPE	325148400	37	HINGE M(STS) L-DOWN	321006700

Online Internet Service
<http://www.icetro.com>

